

SPECIFICATION FOR APPROVAL

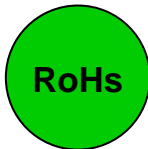

CUSTOMER _____

CUSTOMER'S DWG NO. _____

REVISION NO. _____

CUSTOMER'S PART NO. _____

TECSTAR'S PART NO. _____

TL201212-4R7K _____

QUANTITY _____

PCS _____

ITEM _____

DATE SEP/03/2009 _____

	“√”	CUSTOMER'S SIGNATURE	NOTE
FULL APPROVED			
CONDITONAL APPROVED			
REJECTED			



TECSTAR TECHNOLOGY CO., LTD.

NO. 820-1 Kou Shih Rd. Yang Mei Chen

Taoyuan Hsien, Taiwan, R.O.C.

TEL : 886-3-4788701

FAX : 886-3-4788702

www tecstar.com.tw

SPECIFICATION FOR APPROVAL

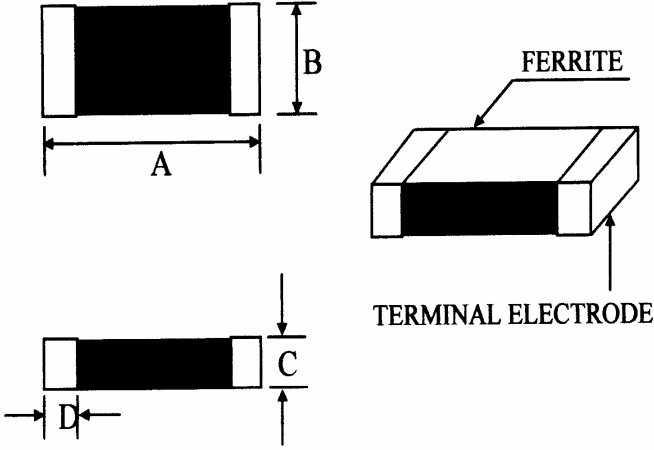
CUSTOMER:			CUSTOMER'S P/N:		
VENDOR'S P/N:			TL201212-4R7K		
DIMENSION:(m/m) 			A	2.0 ± 0.2	m/m
			B	1.2 ± 0.2	m/m
			C	1.2 ± 0.2	m/m
			D	0.5 ± 0.3	m/m
			E		
			F		
			G		
			H		
			I		
			J		
			K		
			L		
			M		
			N		
			O		
ELECTRICAL REQUIREMENTS			TEST INSTRUMENTS		
L	4.7 ± 10%	μH	TEST FREQ.	●HP 4338A MILLIOHMMETER	
Q	45	MIN.	TEST FREQ.	○HP 4195A NETWORK/SPECTRUM ANALYZER	
Srf	35	MHz MIN.	TEST FREQ.	○HP 4284A BIAS CURRENT SOURCE	
Rdc	1.00	OHM. MAX.	TEST FREQ.	○HP 4285A PRECISION LCR METER	
Idc	30	mA MAX.	TEST FREQ.	○HP 4286A PRECISION LCR METER	
			●HP 4291B RF IMPEDANCE /MATERIAL ANALYZER		
			○HP 6632A DC POWER SUPPLY		
DRAWN BY		CHECKED BY		APPROVED BY	
Juli Wang		John Chuang		Lionel Lin	

TEST DATA

CUSTOMER:							
CUSTOMER'S P/N:						SERIES NO:	TL2674
VENDOR'S P/N:		TL201212-4R7K				DATE:	03-SEP-2009
MEAS	A	B	C	D	L	Q	Rdc
ITEM	(m/m)	(m/m)	(m/m)	(m/m)	(μ H)		(Ω)
SPEC	2.0 ± 0.2	1.2 ± 0.2	1.2 ± 0.2	0.5 ± 0.3	$4.7 \pm 10\%$	45 MIN.	1.00 MAX.
TEST FREQ.					10 MHz	10 MHz	
1	2.04	1.22	1.25	0.52	4.30	71.4	0.615
2	2.01	1.25	1.23	0.50	4.47	69.1	0.633
3	2.00	1.23	1.21	0.52	4.78	71.6	0.644
4	2.03	1.21	1.22	0.54	4.64	72.3	0.625
5	2.02	1.22	1.20	0.52	4.83	75.2	0.585
6	2.01	1.24	1.24	0.48	4.37	69.1	0.642
7	2.04	1.23	1.22	0.54	4.59	70.8	0.613
8	2.02	1.22	1.23	0.53	4.88	67.5	0.597
9	2.00	1.24	1.21	0.54	4.31	72.9	0.588
10	2.01	1.23	1.22	0.52	4.76	71.3	0.609
AVG	2.02	1.23	1.22	0.52	4.59	71.1	0.615
R	0.04	0.04	0.05	0.06	0.58	7.7	0.059
DRAWN BY			CHECKED BY			APPROVED BY	
Juli Wang			John Chuang			Lionel Lin	

TYPICAL ELECTRICAL CHARACTERISTICS CURVE

TL2012 Type

Inductance VS. Frequency

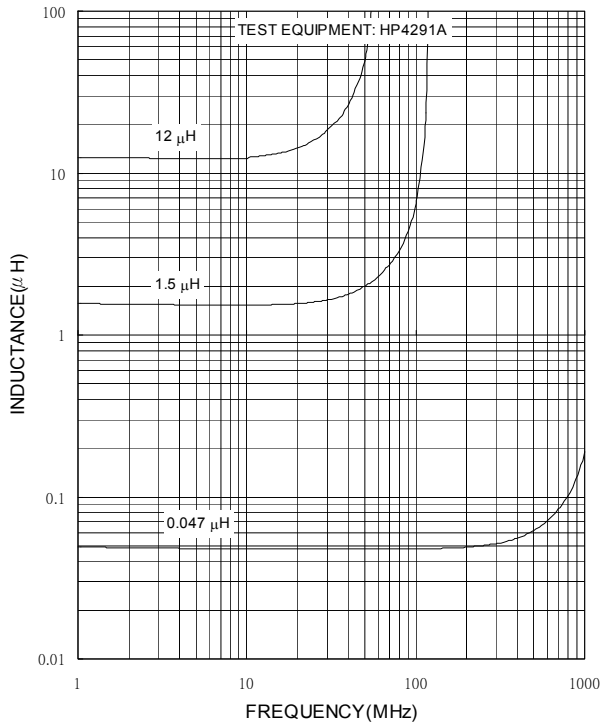

Impedance VS. Frequency

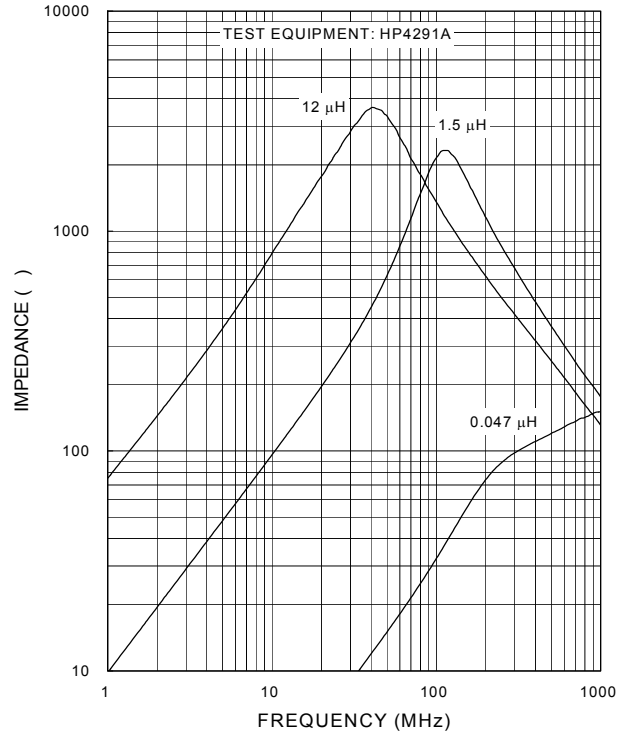

Inductance VS. Temperature

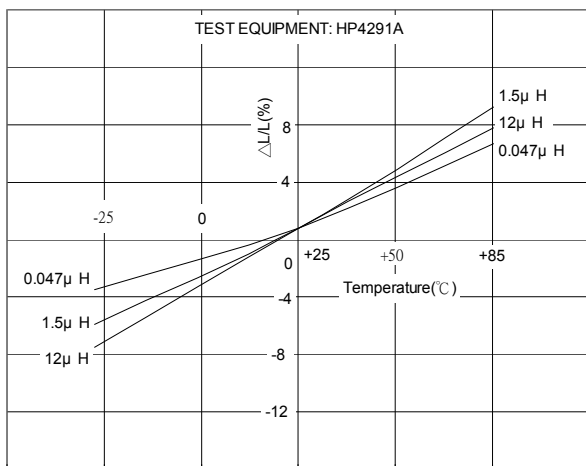

Q VS. Frequency

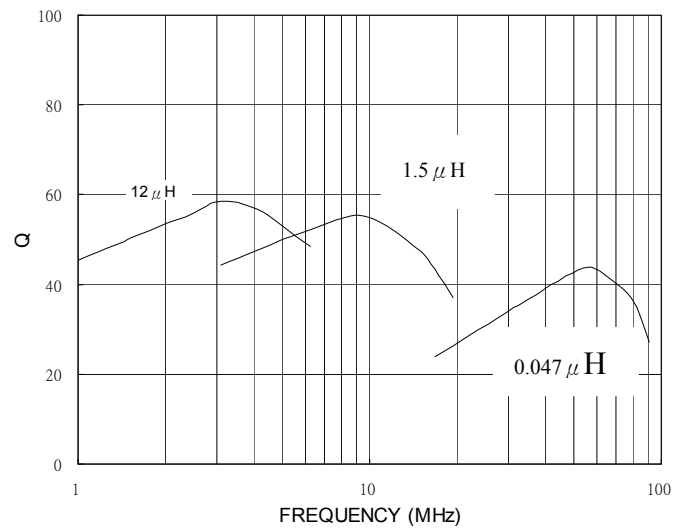

RELIABILITY TEST

Item	Performance	Test condition
Operating temperature range	-55 °C to + 125 °C	
Storage temperature and umidity ranges	40 °C MAX., 70% RH MAX.	
Soldering heat resistance	The chip shall not be cracks. More than 75% of terminal electrode shall be covered with solder.	Preheat: 150 °C, 60 seconds Solder temperature : 260 ± 5 °C Flux: Rosin Dip time: 10 ± 1 seconds
Solderability	More than 90% of the terminal electrode shall be covered with new solder.	Preheat: 150 °C, 60 seconds Solder temperature: 245 ± 5 °C Flux: Rosin Dip time: 4 ± 1 seconds

Recommended Soldering Conditions

(REFLOW TEMPERATURE PROFILE) Lead-Free

A	$260 \pm 5^{\circ}\text{C}$
B	$230 \pm 5^{\circ}\text{C}$
C	$30 \pm 10 \text{ sec}$
D	150°C
E	180°C
F	$90 \pm 30 \text{ sec}$

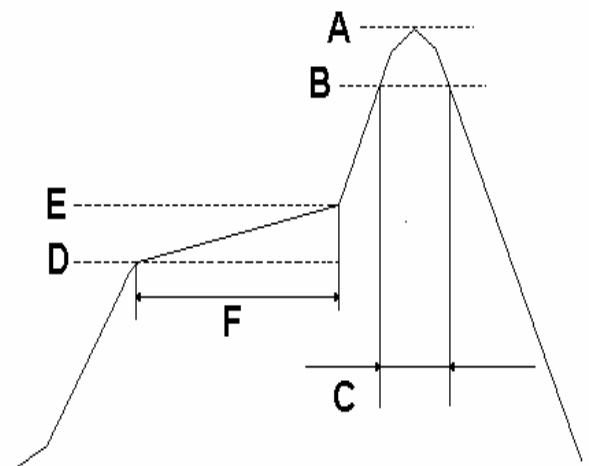

RELIABILITY TEST

Terminal strength

The terminal electrode and the body shall not be damaged by the forces applied on the right conditions.

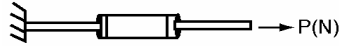

Type	P (kgf)	Time (s)
T□100505	0.3	
T□160808	0.5	
T□201209	0.6	
T□201212	0.8	
T□321611	1.0	
T□322513	1.0	30 ± 5
T□451616	1.0	
T□453215	1.5	
TA3216M4	0.5	

Bending strength

The body shall not be damaged by the forces applied on the right conditions.

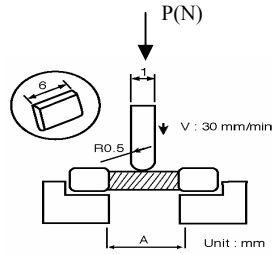

Type	A (mm)	P (kgf)
T□160808	1.0	0.5
T□201209	1.4	1.0
T□201212	1.4	1.2
T□321611	2.0	2.0
T□322513	2.0	2.5
T□451616	2.5	2.5
T□453215	2.7	2.5
TA3216M4	1.4	1.0

RELIABILITY TEST

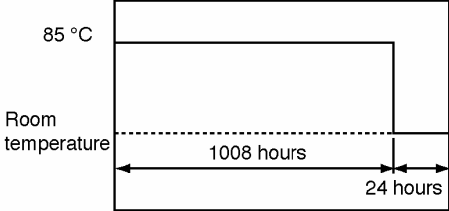
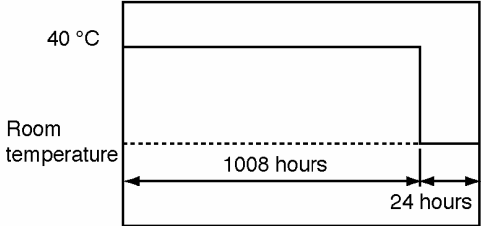
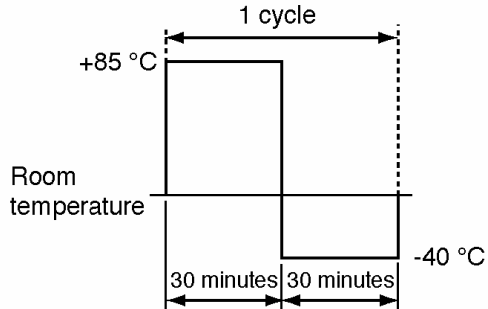
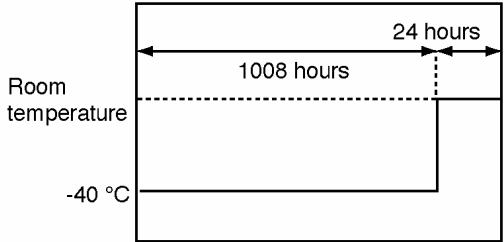
Item	Performance	Test condition
High temperature resistance	Appearance : Ferrite shall not be damaged. Inductance : Within±10% of the initial value. Q: Within±30% of the initial value.	Temperature: 85±2°C Testing time: 1008±12 hours Measurement: After placing for 24 hours min 
Humidity resistance	Appearance: Ferrite shall not be damaged. Inductance: Within±10% of the initial value Q: Within±30 % of the initial value.	Humidity: 90 to 95% RH Temperature: 40±2°C Testing time: 1008±12 hours Measurement: After placing for 24 hours min 
Thermal Shock	Appearance: Cracking, chipping or any other defects harmful to the characteristics shall not be allowed. Inductance: Within±10% of the initial value Q: Within±30% of the initial value.	Temperature: -40°C, +85°C, kept stabilized for 30 minutes each Cycle: 100 cycles Measurement: After placing for 24 hours min 
Low temperature storage life test	Appearance: Cracking, chipping or any other defects harmful to the characteristics shall not be allowed. Inductance: Within±10% of the initial value. Q: Within±30% of the initial value.	Temperature: -40±2°C Testing time: 1008±12 hours Measurement: After placing for 24 hours min 

PACKAGING

- Tape dimensions and packaging quantities

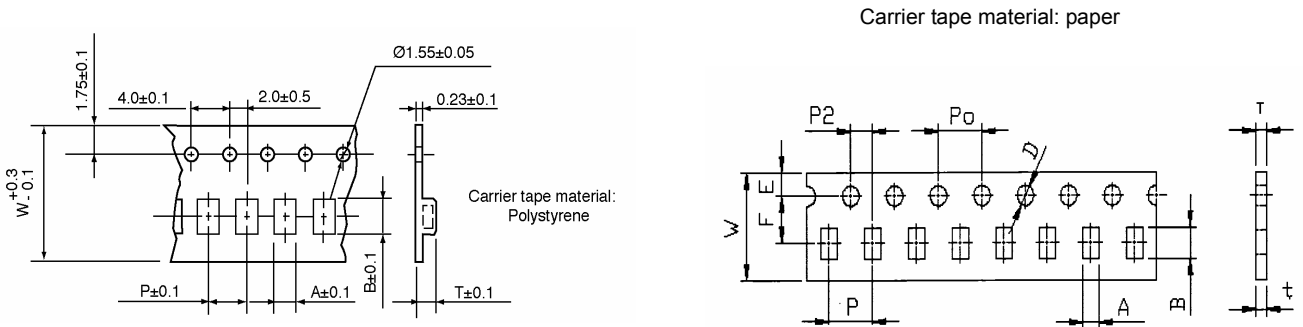

material: Paper (Dimensions in mm)						
TYPE	A	B	W	P	T	CHIPS / REEL
100505	0.62	1.12	8	2	0.60	10000
160808	1.10	1.90	8	4	0.95	4000
201209	1.50	2.30	8	4	0.95	4000
material: Polystyrene (Dimensions in mm)						
TYPE	A	B	W	P	T	CHIPS / REEL
160808	1.01	1.80	8	4	1.02	4000
201209	1.42	2.25	8	4	1.04	4000
201212	1.50	2.35	8	4	1.45	2000
321611	1.88	3.50	8	4	1.27	3000

- Reel dimensions

Material: Paper, Plastic

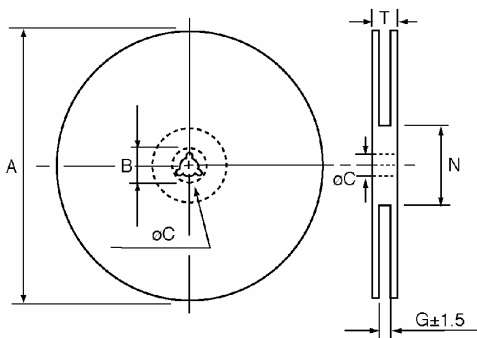

Dimensions in mm

TYPE	8mm	12mm
A	178±2	178±2
B	21.0±0.8	21.0±0.8
C	13.0±0.8	13.0±0.8
G	10.0	14.0
N	75	75
T	12.5	16.5

